



**ASTRONERGY**

**TO BE THE MOST COMPETITIVE  
PHOTOVOLTAIC MODULE  
SUPPLIER WORLDWIDE**



[www.astronergy.com](http://www.astronergy.com)



Contact us: [marketing.astro@Astronergy.com](mailto:marketing.astro@Astronergy.com)



Follow us @Astronergy



Follow us @ Astronergy Solar



[www.youtube.com/@Astronergy](http://www.youtube.com/@Astronergy)

FOR A GREENER WORLD







Tier 1 PV Module Maker listed by BloombergNEF



TOP 6 global shipment



TOP Performer honored by PVEL for 7 times



Overall Highest Achiever



Pioneer in n-type TOPCon PV Modules  
Pioneer and Explorer of Smart Manufacturing in PV

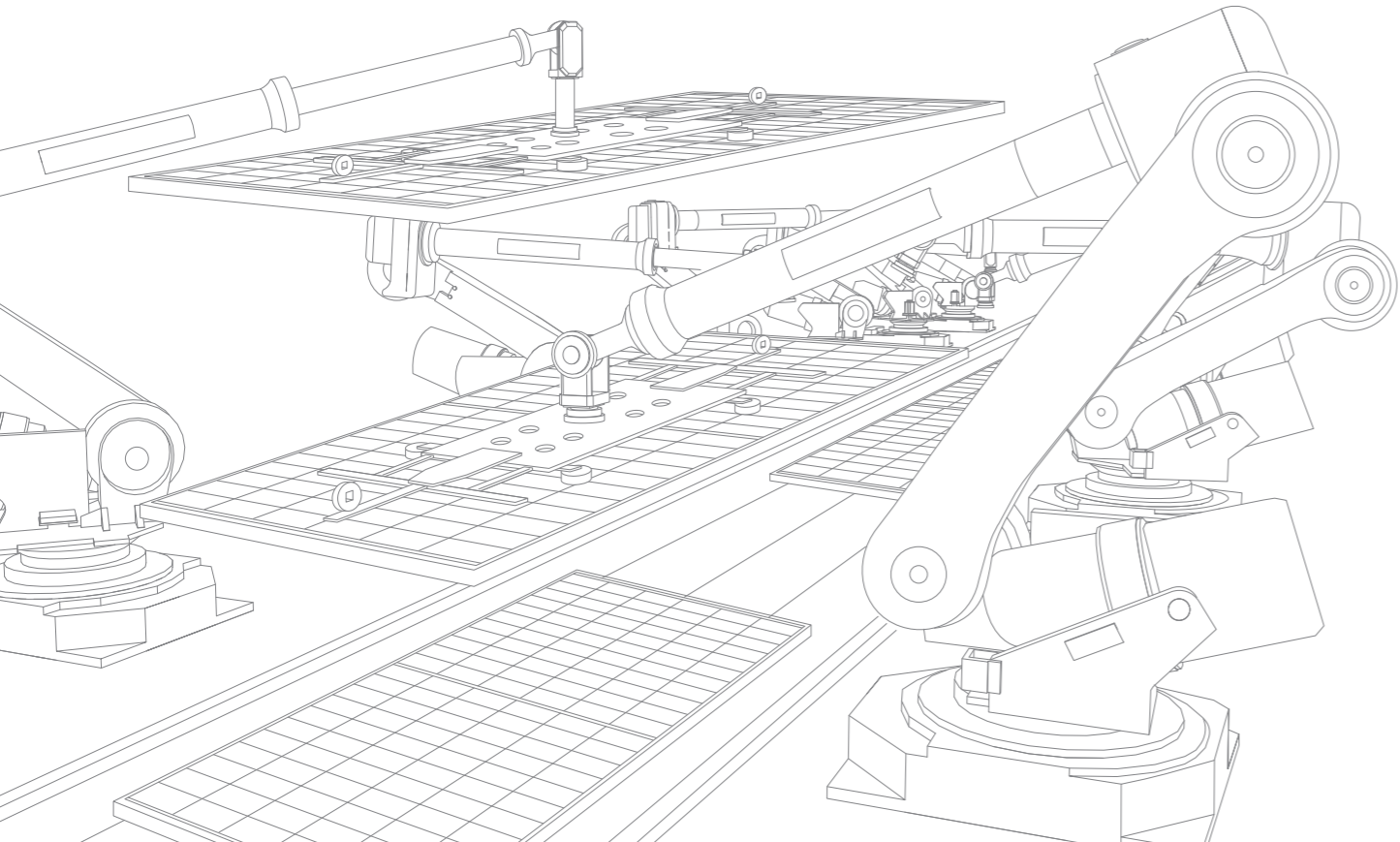

**Company Profile** ..... 01-12

- About CHINT Group 01
- About Astronergy / Sustainability Strategy 03
- Globalization / Milestones 05
- Brand Value / Bankability / Intelligent Manufacturing 09
- R&D Strength 11

**Our Products** ..... 13-16

- n-type TOPCon Modules 13
- p-type Modules 15
- Quality Assurance 16

**Applied Cases** ..... 17-22

- Utility-scale Power Stations 17
- Distributed PV Rooftops 21





**18.34 Billion USD**  
2022 CHINT Group Revenue



**45000+**  
Employees Worldwide



**140 +**  
Countries and Regions Where Businesses Cover



**3.02 Billion USD**  
PV Modules Revenue in 2022



**8.3 Million Tons**  
CO2 Emissions Reduced per Year



**8.3 Billion kWh**  
Green Electricity Provided for the Whole Society per Year

Founded in 1984, CHINT Group Co., Ltd. (hereinafter referred to as "CHINT") is a global leading smart energy solutions provider. Over the past 39 years since its establishment, CHINT has always focused on industry and brand building, deeply implemented the strategy of "Industrialization, Technologization, Internationalization, Digitalization and Platformization", and formed three major segments of "Green Energy, Intelligent Electric and Smart Low-carbon" and two major platforms of "CHINT International Platform and Sci-tech Innovation Incubation Platform", with its business covering more than 140 countries and regions and employees of more than 45,000 worldwide. In 2022, CHINT's operating revenue reached 18.34 billion dollars, and CHINT has been listed among the Top 500 Chinese Enterprises for more than 20 consecutive years. CHINT Electric (stock code: 601877) is the first A-share listed company in China with LV electrical appliances as its main business.

CHINT seizes the new development opportunities of digitalization and dual-carbon goals and continuously strengthens the "One Cloud & Two Nets" strategy. Creating "CHINT Cloud" as the carrier of intelligent technology and data application, leading in building the Energy Internet of Things (EIoT) and Industrial Internet of Things (IIoT) platforms, aspiring to be explorers, advocates, and practitioners in the world of low-carbon development. With the "green energy, smart network, load reduction, and new storage" service systems, CHINT set up a platform-based enterprise, building a regional smart energy industry ecosystem. It provides a total energy solutions package for public institutions, industrial, commercial, and end users to achieve energy conservation, carbon reduction, and accelerate the energy transition.







Under the CHINT Group, Astronergy is an intelligent manufacturing enterprise focusing on photovoltaic cells and modules. Founded in 2006, it is one of the earliest private enterprises in China to set foot in the photovoltaic field.

Committed to be the most competitive photovoltaic module supplier worldwide, Astronergy sets its mission to create a sustainable and net-zero carbon world with solar power. Focusing on R&D, production and sales of high-efficiency crystalline silicon PV cells and PV modules, Astronergy has continuously launched the ASTRO and ASTRO N series high-efficiency, high-quality, high-performance modules. Big-size wafer tech enables both bifacial and monofacial ASTRO and ASTRO N series modules could be perfectly applied in all scenarios such as utility-scale power stations, commercial & industrial (C&I) PV systems and residential

PV systems. Pioneered the mass production of n-type TOPCon PV modules and Astronergy keeps leading in n-type TOPCon PV cell tech.

With business footprints in over 140 countries and regions, Astronergy has established intelligent manufacturing bases at Haining in Zhejiang, Yancheng in Jiangsu, Jiuquan in Gansu, Songyuan in Jilin, Fengyang in Anhui, Yiwu in Zhejiang, Yanchi in Ningxia and in Thailand. It has also set up branch companies and sales centers in countries like Germany, Spain, the Netherlands, Poland, the United States, Canada, Brazil, Australia, Singapore, Japan, and Thailand, achieving great sales performance of Astronergy PV products in international mainstream markets of Europe, North America, Latin America, and Asia Pacific.



**60 GW+**  
Total Global Shipments



**55 GW**  
2023 Estimated PV Modules Capacity



**53 GW**  
2023 Estimated PV Cells Capacity



**100 GW+**  
2025 Estimated PV Modules Capacity



**90 GW+**  
2025 Estimated PV Cells Capacity

**ZERO** **BY 2050**  
Carbon Neutrality

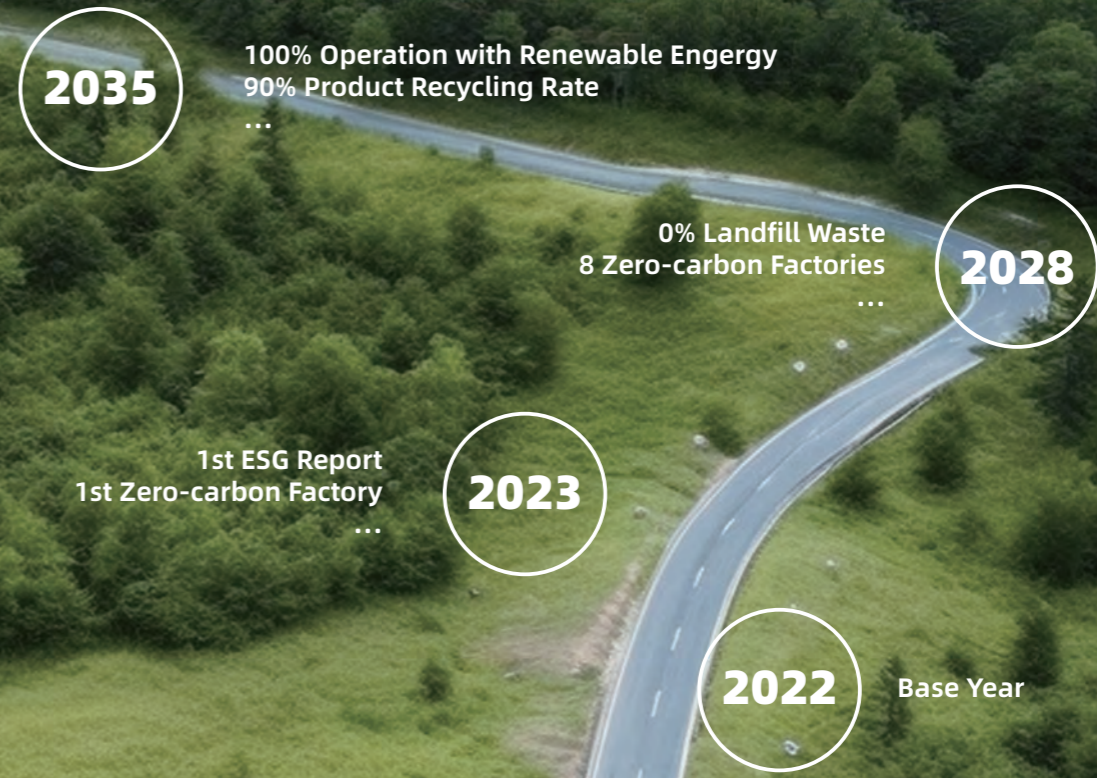



# Globalization

Astronergy product sales footprint covers more than 140 countries around the world. And it has set up branches in the United States, Germany, Australia, Canada, Singapore, Thailand, Japan and other countries to help the process of globalization and win the full trust of customers and good reputation in the industry with credibility.

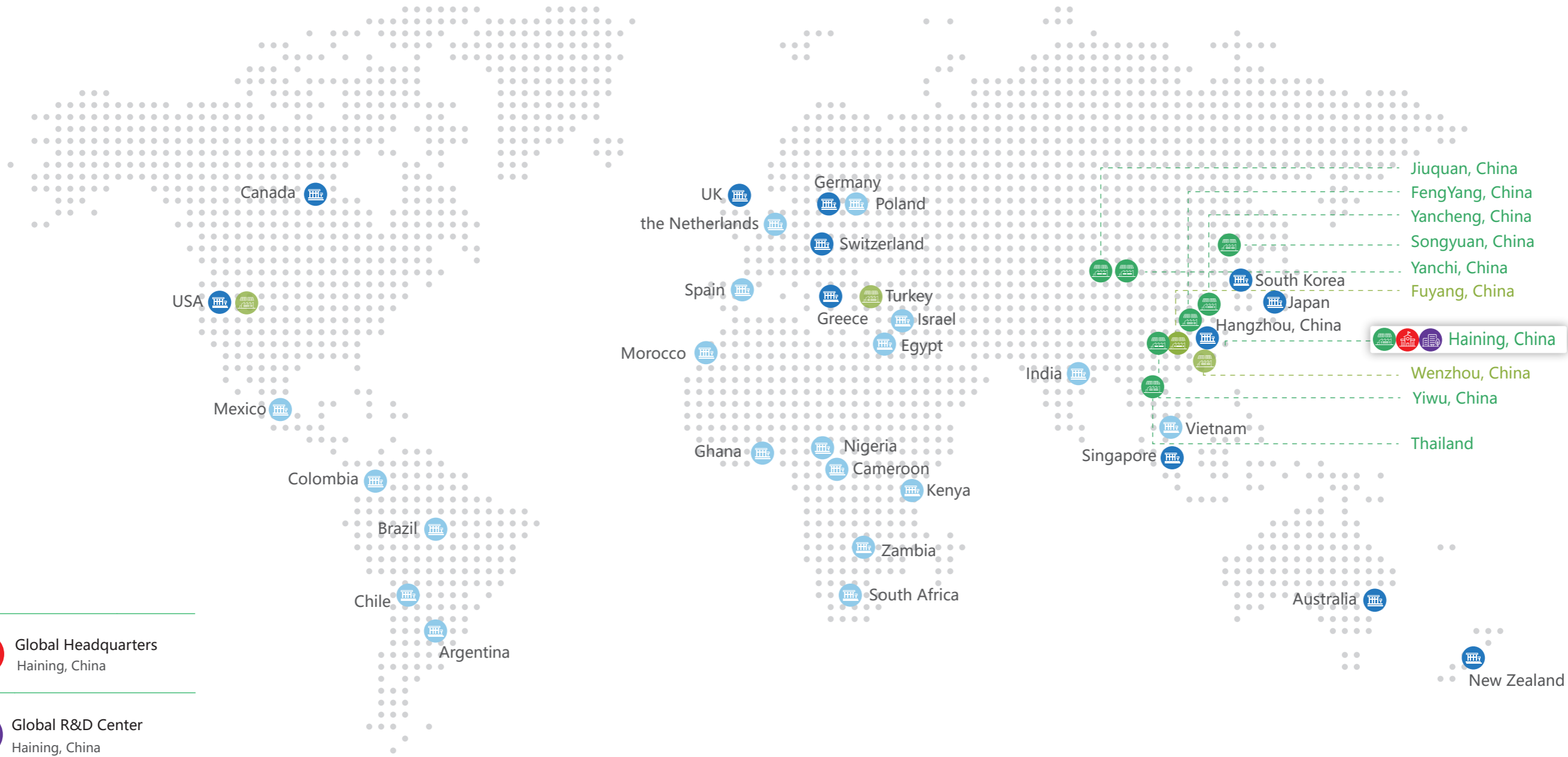

Global Headquarters  
Haining, China

Global R&D Center  
Haining, China

Global Sales Offices  
Hangzhou, China    Canada  
USA                    Singapore  
Germany            Thailand  
Australia            Japan  
South Korea        ...

Global Manufacturing Bases (Mass Production)  
Haining, China    Fengyang, China  
Yancheng, China    Yiwu, China  
Jiuquan, China    Yanchi, China  
Songyuan, China    Thailand

Global Sales Channels  
Spain                    Morocco  
the Netherlands    Chile  
Brazil                    Israel  
India                    Argentina  
Poland                    Vietnam  
Egypt                    Mexico  
Colombia                ...

Global Manufacturing Bases (under construction)  
Wenzhou, China  
Fuyang, China  
USA  
Turkey





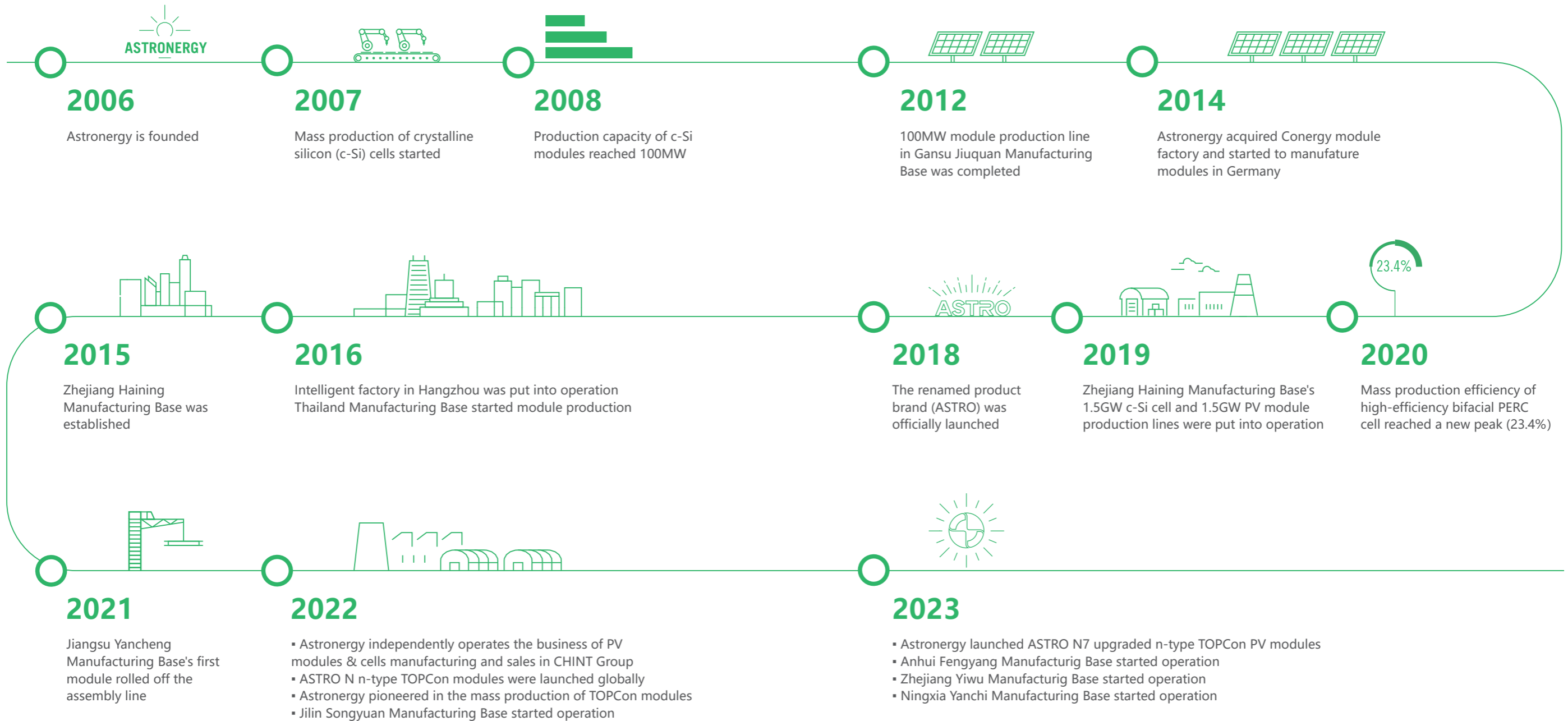





# Milestones





# Brand Value

 <p>For 7 years, Astronergy has been honored by PVEL as "TOP Performer" among module manufacturers</p>	 <p>Astronergy has won 8 awards of "All Quality Matters" from TÜV Rheinland</p>	<p><b>Tier 1</b> BloombergNEF</p> <p>For a long time, Astronergy has been listed as the world's Tier 1 PV Module Maker by Bloomberg NEF</p>
 <p>TOP 10 PV Modules Suppliers released by S&amp;P Global</p>	 <p>No. 1 in "China's Top 100 Private Enterprises with Social Responsibility" in 2022</p>	 <p>No. 82 in "2022 China's Top 500 Private Enterprises"</p>
 <p>No. 235 in "2021 Top 500 Chinese Enterprises"</p>	 <p>China Industry Award</p>	 <p>China Charity Award</p>

# Bankability

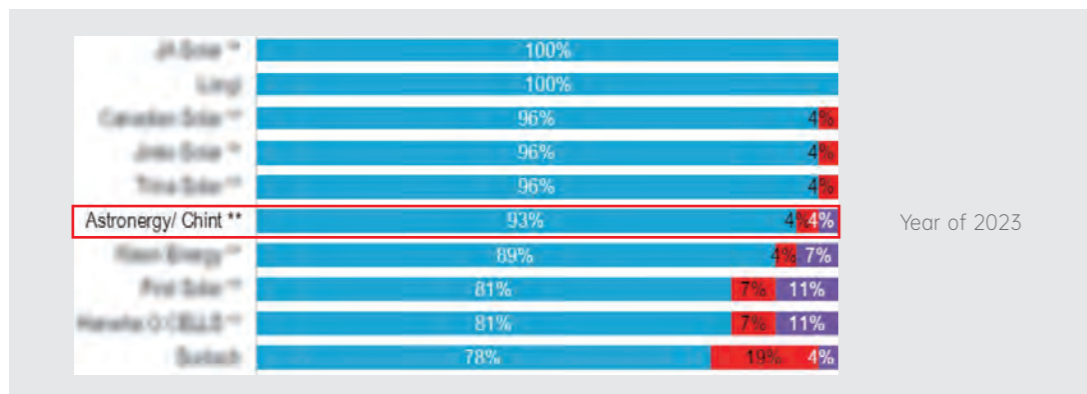

In the annual "PV Module and Inverter Bankability" released by Bloomberg New Energy Finance (BNEF), Astronergy bankability rating has risen from seventh place on the 2022 list to sixth place on the 2023 list.



# Intelligent Manufacturing

 **Pioneer and Explorer of Smart Manufacturing in PV**  
Astronergy builds the first PV "Intelligent Manufacturing" transparent factory

With the automatic production line and highly information-integrated production mode, Astronergy enables the monitoring and traceability in the production process from raw materials to finished products and maintains its leading position in smart manufacturing.

- |  |  |   |
|--|--|---|
|  <b>1st to Achieve AI Automatic Detection of EL Defects</b> | * Supported by Big Data                                    | * AI Quality Detection                                    |
|  | * Localization of Production Equipment                     | * Automatic Monitoring of the Entire Process              |
|  <b>Outstanding in Intelligent Manufacturing</b>            | * Fully Automated Production                               | * Automatic Batching by Unmanned Vehicles                 |
|  | * Sino-German Intelligent Manufacturing Demonstration Base | * Intelligent Photovoltaic Pilot Demonstration Enterprise |

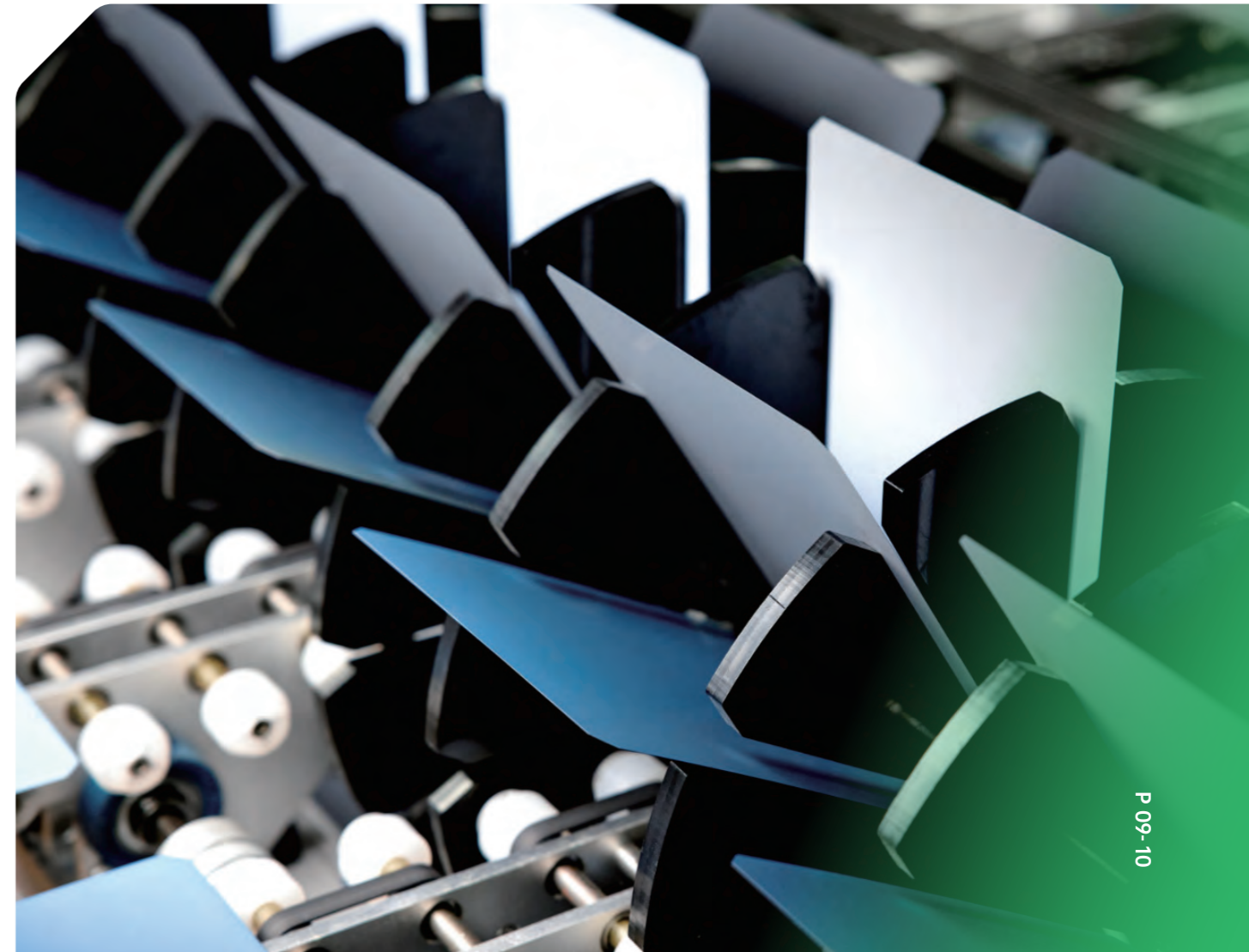



# R&D Strength

## Global R&D Cooperation

Explore the "industry university research" integration made with Shanghai Jiao Tong University, Zhejiang University, Zhejiang University of Technology, Hangzhou University of Electronic Science and Technology, New South Wales, Chinese Academy of Sciences Ningbo Institute of Materials and other universities and research institutions, integrate global innovation resources, and promote enterprise R&D innovation and talent training. Deeply cooperate with domestic and foreign frontline equipment and material manufacturers, carry out collaborative innovation in the industrial chain, and promote industry material innovation and industrialization.



**Zhejiang University**  
Key Technologies of Low-cost and High-efficiency Solar Cells



**Shanghai Jiao Tong University**  
New Tunnel Passivated High-efficiency Solar Cell & Module Technology



**Zhejiang University of Technology**  
N-type Passivated Contact High-efficiency Bifacial Crystalline Silicon Solar Cells



**Hangzhou Dianzi University**  
High-efficiency Monocrystalline PERC Cell Technology



**UNSW SYDNEY**  
Hydrogen Passivation Project

## Accreditation Laboratory Qualifications

With strong testing capabilities, Astronergy has obtained the qualifications of CNAS Laboratory, CSA Witness Laboratory, TÜV Rheinland Witness Laboratory, Intertek "Satellite Program" Laboratory and other qualifications, and conducts more than 30 rigorous tests internally for PV modules.

## Scientific Research Achievements

232 Utility Model Patents

72 Invention Patents

7 Appearance Design Patents

## Scientific Projects and Talent Declaration

**20%+** The number of R&D personnel with intermediate titles and above at the national level accounts for more than 20%

**Handshake icon** Zhejiang Core Energy's Key Cooperative R&D Projects

**Head with gears icon** Jiaxing Leading Team on Innovation

**Microscope icon** Haining Demonstration Project on Collaborative Innovation

## Leading in Cell & Module Efficiency

**Cell icon** Mono- PERC cell efficiency is **23.4%**, leading in PV industry

**N icon** The average efficiency of massively produced n-type TOPCon cells reaches **25.75%**  
The average optimal efficiency of n-type TOPCon produced from pilot line hits **26.4%+**



# Our Products\_\_n-type TOPCon Ultra-High Power Modules

**Astronergy is a pioneer in n-type TOPCon PV modules.**

ASTRO N series adopts n-type TOPCon PV cell technology, featured advanced technologies such as multi-busbar (MBB) half-cut wafer (N7 adopts the latest SMBB half-cut wafer), non-destructive cutting, high-density encapsulation, etc., to achieve advantages such as high power, high efficiency, high reliability, high power generation per watt, low BOS and low LCOE, and can meet the needs of multiple scenarios such as utility-scale power plants, commercial and industrial distributed power plants, and residential power plants.

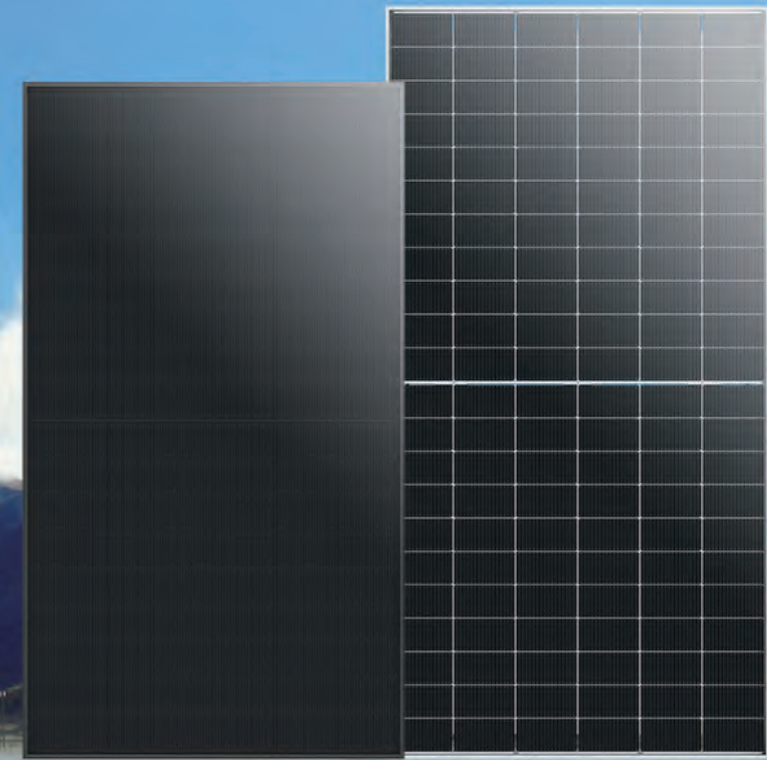

## **ASTRO N7**

**615W / TOPCon 3.0 / Rectangular Wafer**

SMBB Cell Tech / Light Redirecting Film For Dual-glass Products



### **Application Scenarios:**

Utility-scale Power Stations and Distributed Power Stations



## **ASTRO N5**

**585W / 182mm Wafer**



### **Application Scenarios:**

Utility-scale Power Stations and Distributed Power Stations



## **ASTRO N7s**

**460W / TOPCon 3.0 / Rectangular Wafer**

ZBB-TF Cell Tech



### **Application Scenarios:**

Residential Rooftop Solar Power Systems and C&I Distributed Solar Power Systems

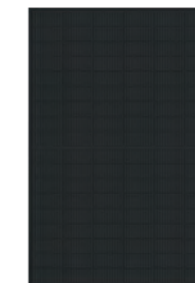

## **ASTRO N5s**

**430W / 182mm Wafer**



### **Application Scenarios:**

Residential Photovoltaic Rooftops

# Our Products **High-efficiency PERC/PERC+**

# Quality Assurance

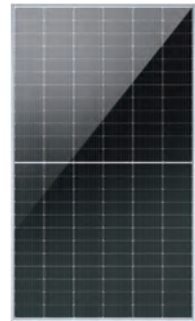

**ASTRO 5** 555W / 182mm Wafer  
Suitable for utility-scale power stations and distributed power stations



Featuring five core strengths of high power, high efficiency, high compatibility, high quality and low BOS & LCOE, ASTRO 5 Series adopts Astronergy PERC+ cell technology and 182mm large-size silicon wafer, and combines non-destructive cutting, suitable for utility-scale power stations and distributed power stations.

- HIGH** power
- HIGH** efficiency
- HIGH** compatibility
- HIGH** quality
- LOW** BOS & LCOE

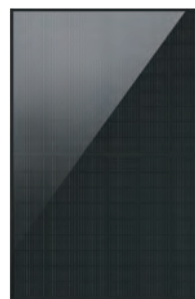

**ASTRO 5s** 415W / 182mm Wafer  
Meet the differentiated needs of international residential PV market



Featuring "light, efficient, quality and aesthetic", Astronergy ASTRO 5s is an ultra-high-value module product to meet the differentiated needs of residential PV market, especially for the international residential PV market.

- HIGH** power
- HIGH** efficiency
- HIGH** quality
- EASY** installation

## Warranty \* n-type TOPCon products

<b>15</b> Years	<b>30</b> Years	<b>≤1.0%</b>	<b>≤0.4%</b>
Product Warranty Period	Power Warranty Period	First-year Power Degradation	Annual Power Degradation

## \* p-type Double-glass products

<b>15</b> Years	<b>30</b> Years	<b>≤2.0%</b>	<b>≤0.45%</b>
Product Warranty Period	Power Warranty Period	First-year Power Degradation	Annual Power Degradation

## \* p-type Single-glass products

<b>12</b> Years	<b>25</b> Years	<b>≤2.0%</b>	<b>≤0.55%</b>
Product Warranty Period	Power Warranty Period	First-year Power Degradation	Annual Power Degradation

## Certificates

Our products have been awarded a variety of international certificates. Astronergy cooperates with top international laboratories for its product evaluation, such as TUV, UL, CEC, CQC, INMETRO, KS, etc. The quality policy of Astronergy is to create a world-famous brand and to lastingly provide satisfied products and solutions for customers.



## Reliability

Our products have passed the tests of dynamic mechanical load, Ammonia corrosion, Salt mist corrosion, Dust and sand, PID, LETID, Transportation, etc.





# Applied Cases \_ Utility-scale PV Power Stations



103MW Midden-Groningen Solar Park  
📍 The Netherlands



50MW Barreiras Project  
📍 Brazil



150MW Agriculture-Solar Hybrid PV Power Station  
📍 Wenzhou, Zhejiang Province, China



70MW Utility-scale Project in Zhangjiakou  
📍 Zhangjiakou, Hebei Province, China



132MW Claresholm Solar Farm  
📍 Southern Alberta, Canada



200MW Forest-Solar Hybrid Power Station  
📍 Jiangshan, Quzhou, Zhejiang Province, China



89MW Goonumbbla Project  
📍 Australia



310MW China's First Sand-Solar Hybrid Power Station  
📍 Kubuqi, Inner Mongolia, China



550MW The Largest Fishing-Solar Hybrid Project in Asia  
📍 Wenzhou, Zhejiang Province, China



165MW Benban Solar Park Project  
📍 Egypt



48.5MW Insua Power Station  
📍 Portugal



# Applied Cases **Utility-scale PV Power Stations**





# Applied Cases **Distributed Rooftop PV Power Stations**



**10MW** Roof Photovoltaic Power Station of Hangzhou East Railway Station  
 Hangzhou, Zhejiang Province, China

**\* 4.2MW**  
 Rooftop Project of Hangzhou South Railway Station  
 Hangzhou, Zhejiang Province, China

**\* 4MW**  
 Project "Million Rooftops for Zhixi"  
 Quzhou, Zhejiang Province, China

**\* 23MW**  
 C&U Group Rooftop Project  
 Wenzhou, Zhejiang Province, China

**\* 20MW**  
 Roof Project in Changxing Economic and Technological  
 Development Zone  
 Huzhou, Zhejiang Province, China

**\* 10MW**  
 Logistics Warehouses Rooftop Solar Projects  
 Serbia

**\* 16kW**  
 Hervey Bay Rooftop  
 Australia



**1.2MW** Hangzhou Civic Center Podium Roof Photovoltaic Power Station  
 Hangzhou, Zhejiang Province, China



**10.3MW** Geely Automobile PV Rooftop Project in Linhai  
 Linhai, Zhejiang Province, China



**10MW** Hikvision Rooftop Project  
 Hangzhou, Zhejiang Province, China



**30MW** Jintian Copper BIPV Power Station  
 Ningbo, Zhejiang Province, China